



STOCK 29 (PO-2025-101)

Thank you for your interest in Cibes Lift Group products. It is our hope that this graphical catalog showcasing your customized Voyager V80 assists you in your decision process. Due to limitations of technology and this being an new system, we note that computerized renderings have limitations for exact color, texture and dimensional tolerances and that slight deviations may be present. The renderings do not include all the details of our lift and are for reference only. Refer to our experienced staff for final details. We will constantly update this system to improve and appreciate your inquiry.

Cibes Lift Group



MODEL: ELEGANCE

PATTERN: BLACK

PLATFORM COLOR: ORIENTAL GREY BEIGE

SHAFT COLOR: ORIENTAL GREY BEIGE

NUMBER OF STOPS: 2

PLATFORM SIZE: L - 1000 X 1467 MM

SHAFT RENDERS



SHAFT RENDERS



DOOR RENDERS



PLATFORM RENDERS





All shaft measurements are in Millimeters (mm)

APPROVED & READ

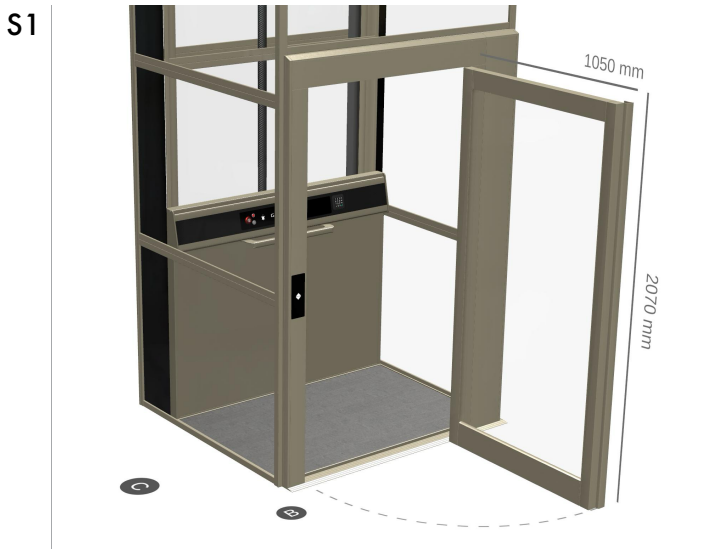
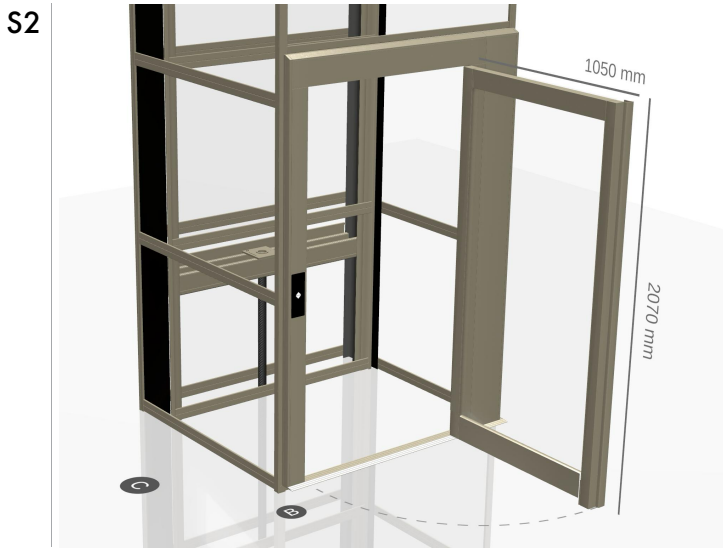

| | | | |
|--------|---|--------|---|
| Door 3 | - | Door 6 | - |
| Door 2 | B | Door 5 | - |
| Door 1 | B | Door 4 | - |



APPROVED & READ



Platform Details

| | |
|---------------|---------------------|
| Pattern | Black |
| Floor | Black Pine |
| Control Panel | Touchscreen w/o FLI |
| Handrail | Compact Handrail |
| Phone | Available |
| Control Box | Not Applicable |
| Front Cover | Not Applicable |

APPROVED & READ

TECHNICAL DETAILS & OTHER COMMENTS

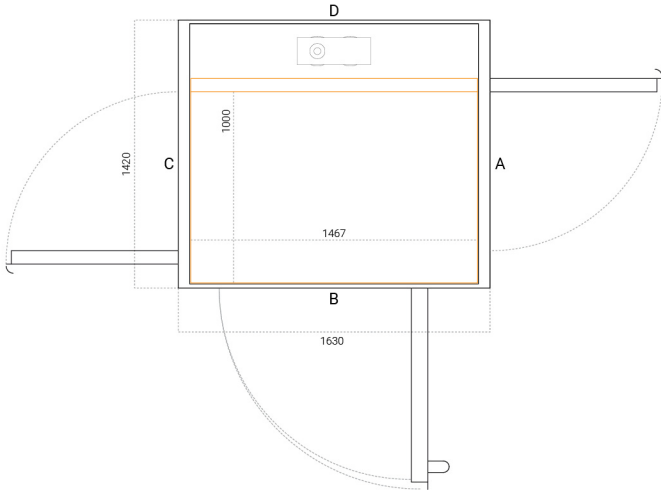

| SIZE DETAILS | A/C | B/D |
|------------------------|------|------|
| Platform Size: | 1000 | 1467 |
| Finished Size: | 1360 | 1509 |
| Cutout Size: | 1420 | 1630 |
| Door Opening w. | 900 | 1050 |

| PANEL DETAILS | |
|-----------------------|---|
| Panels Count: | 7 |
| Custom Panels: | 2 |

ADDITIONAL FEATURES

Eco Silent

COMMENTS

| | |
|----------------------|--|
| A SIDE MODIFICATIONS | |
| B SIDE MODIFICATIONS | |
| C SIDE MODIFICATIONS | |
| D SIDE MODIFICATIONS | |
| E SIDE MODIFICATIONS | |
| SPECIAL NOTES | |



CIBES LIFT

DETAILED CONFIGURATION

PROPOSAL FOR STOCK 29 (PO-2025-101)

#FQ30135599134

MODEL: ELEGANCE

PATTERN: BLACK

04-28-2025

Cibēs

Cutout dimension see sheet 2,
forces see sheet 3

*To be adapted on site
**Customized panel

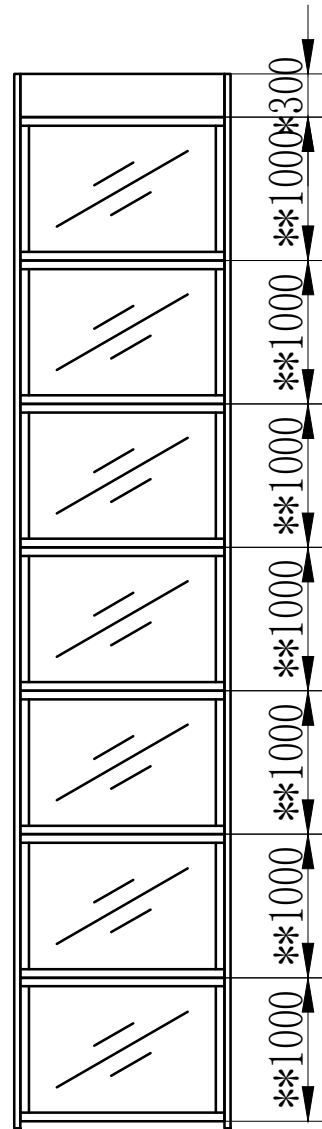

E

Positioning of machinery:

E=Shield wall

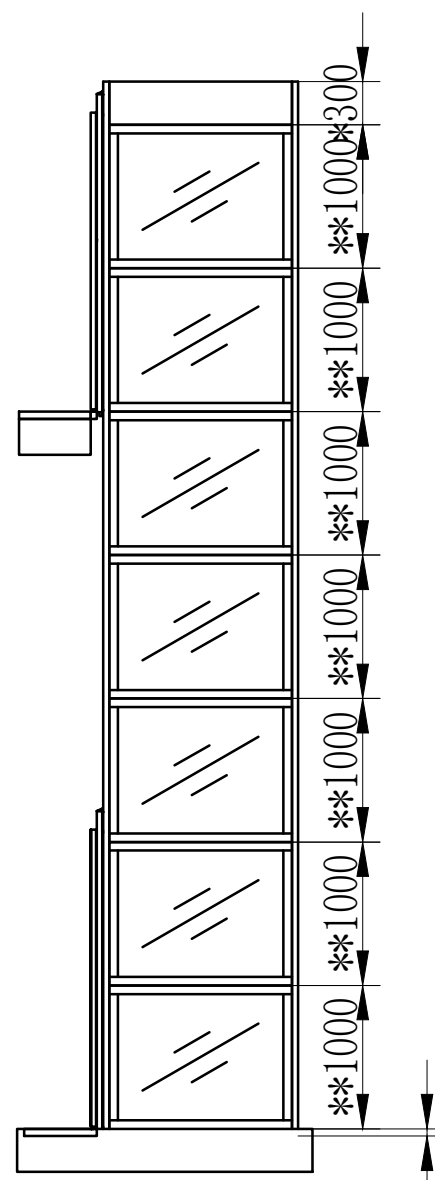
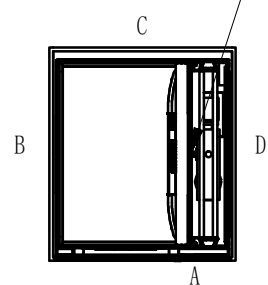

A

50mm pit depth

1509 Lift shaft dimension

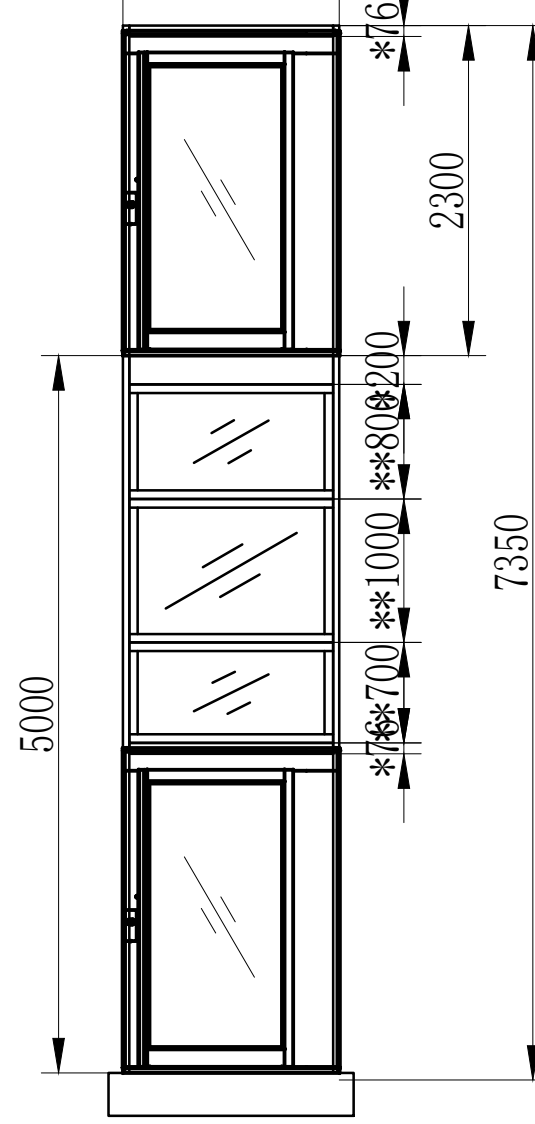

B

1360 Lift shaft dimension

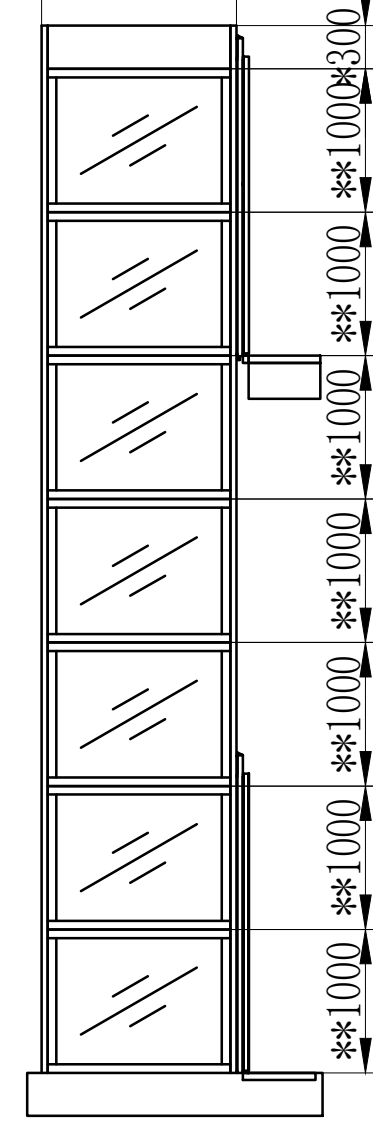

C

Fixing points, 250 N

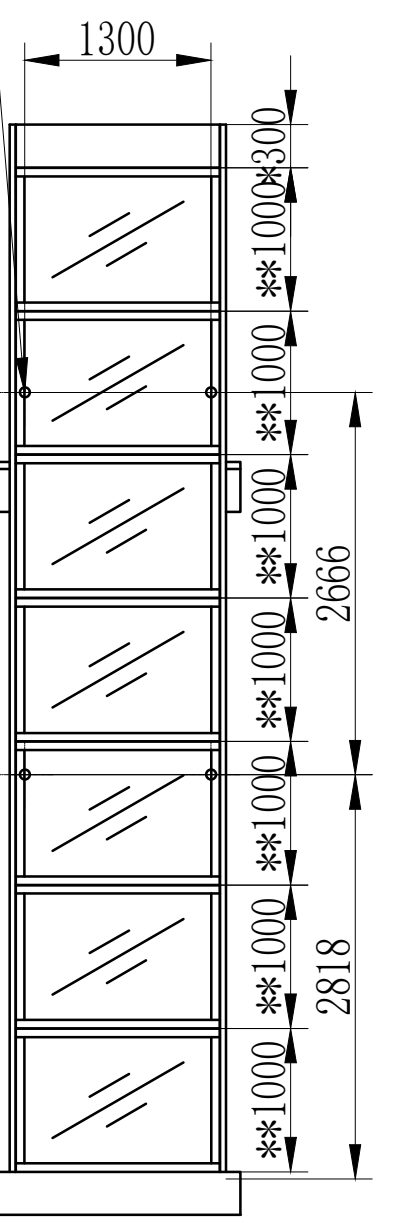

D

Options
Freq. 1x220V 50-60Hz 16A
Capacity:400kg

Approved by
builder:

European view placement:



EOS ID
L00017807

Tender no

Order no

ISO 2768-1 m

Principal drawing

Voyager-1000*1467

Stock29_Ma
rinaQatar

Date
2025-04-28

sheet
1 of 6

Scale:
A3, 1:100

Shaft cutout sizes

Lift unit installed within a shaft by others

| Door front cutout sizes | | |
|-------------------------|-------|--------|
| Landing | Width | Height |
| BG | 1630 | 2250 |
| B1 | 1630 | 2250 |
| | | |
| | | |
| | | |

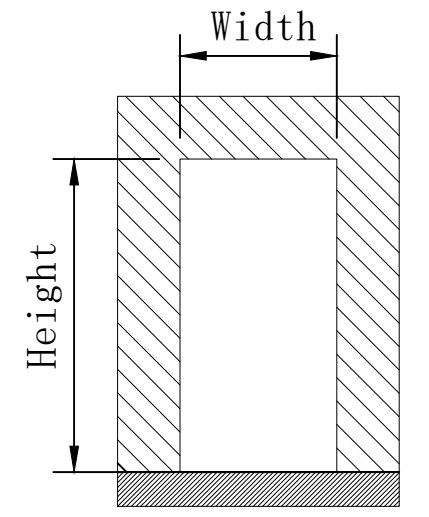
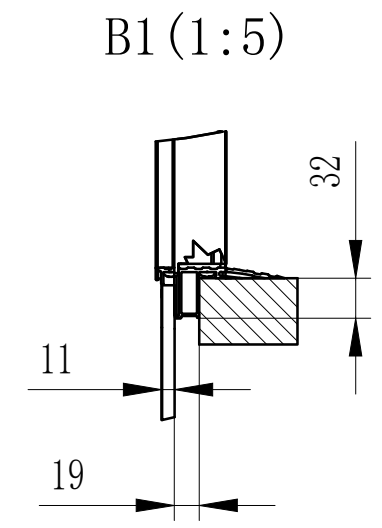
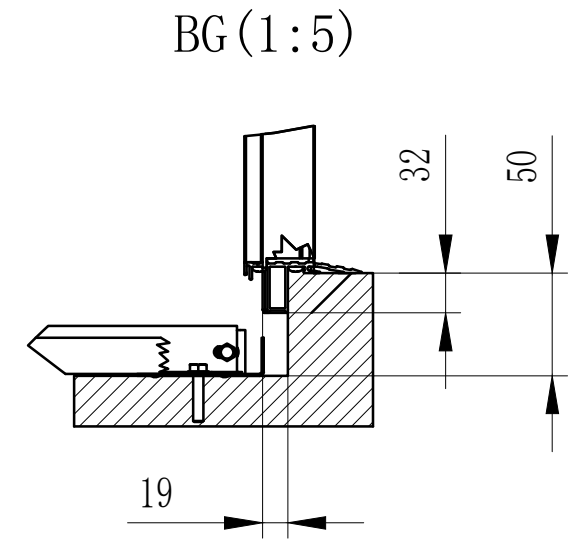
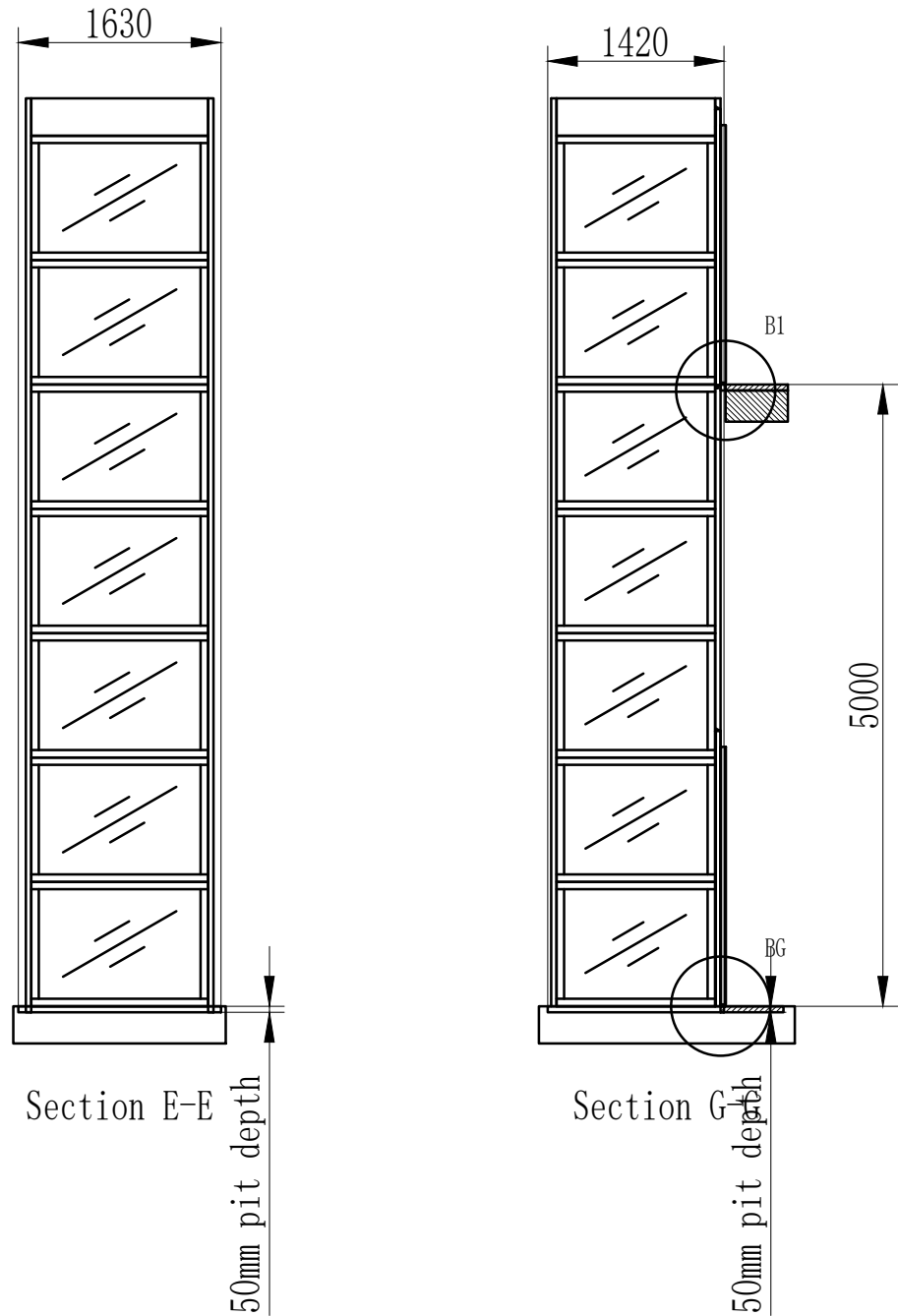

Door cut out

50 mm pit depth + 10 mm, - 0 mm. Bottom surface must be flat

Incoming power supply is connected at landing:
 For wiring and power supply, refer to the unit's wiring diagrams.
 Ceiling shaft lighting, is independent from the power cable and pulled back into the trench's upper part. Shaft lighting > 50 lux.
NOTE! An effective emergency telephone is required for approved inspection.
 The purchaser is responsible for an active phone line being present prior to the lift installation.
 The incoming telephone line is connected to CiLow (TELE). Refer to wiring diagram.
 The emergency signal device is powered by the lift's own battery in the event of a power failure.
 The lift must be equipped with a two-way communication, either via the standard telephone or via the lift telephone, which automatically calls the alarm control center or the like.
NOTE! A lift featuring a frequency converter cannot be directly connected to a RCD.



Approved by builder:

 European view placement



| | | | |
|---------------------|-------------------------|-----------------|---------------------|
| EOS ID L00017807 | Principal drawing | | |
| Tender no | Voyager-1000*1467 | | |
| Order no | Stock29_Ma rinaQatar | | |
| ISO 2768-1 m | Date 2025-04-28 | sheet 2 of 6 | Scale: A3, 1:100 |

6 5 4 3 2 1

D

D

Loads sustained by shaft and platform
and fixing points bottom frame



L section force:
6.98kN



Mast force:12.12kN

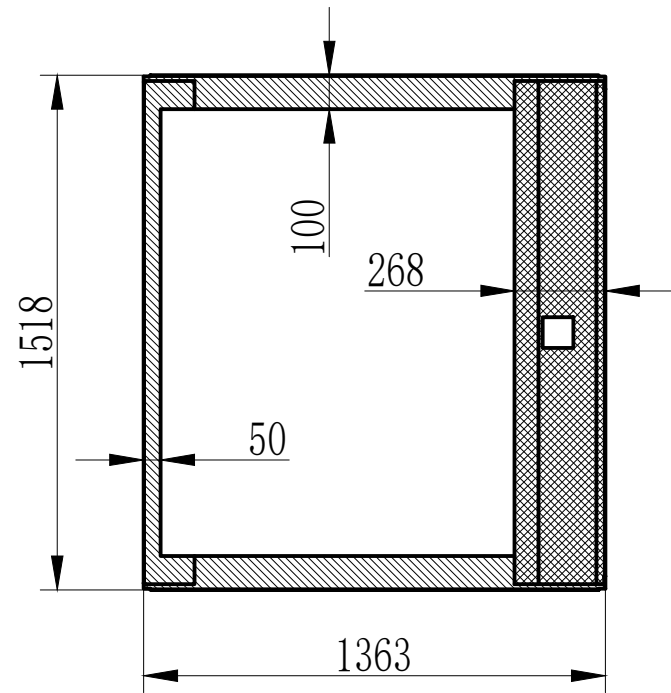

Fixing points, 250 N
See detail A

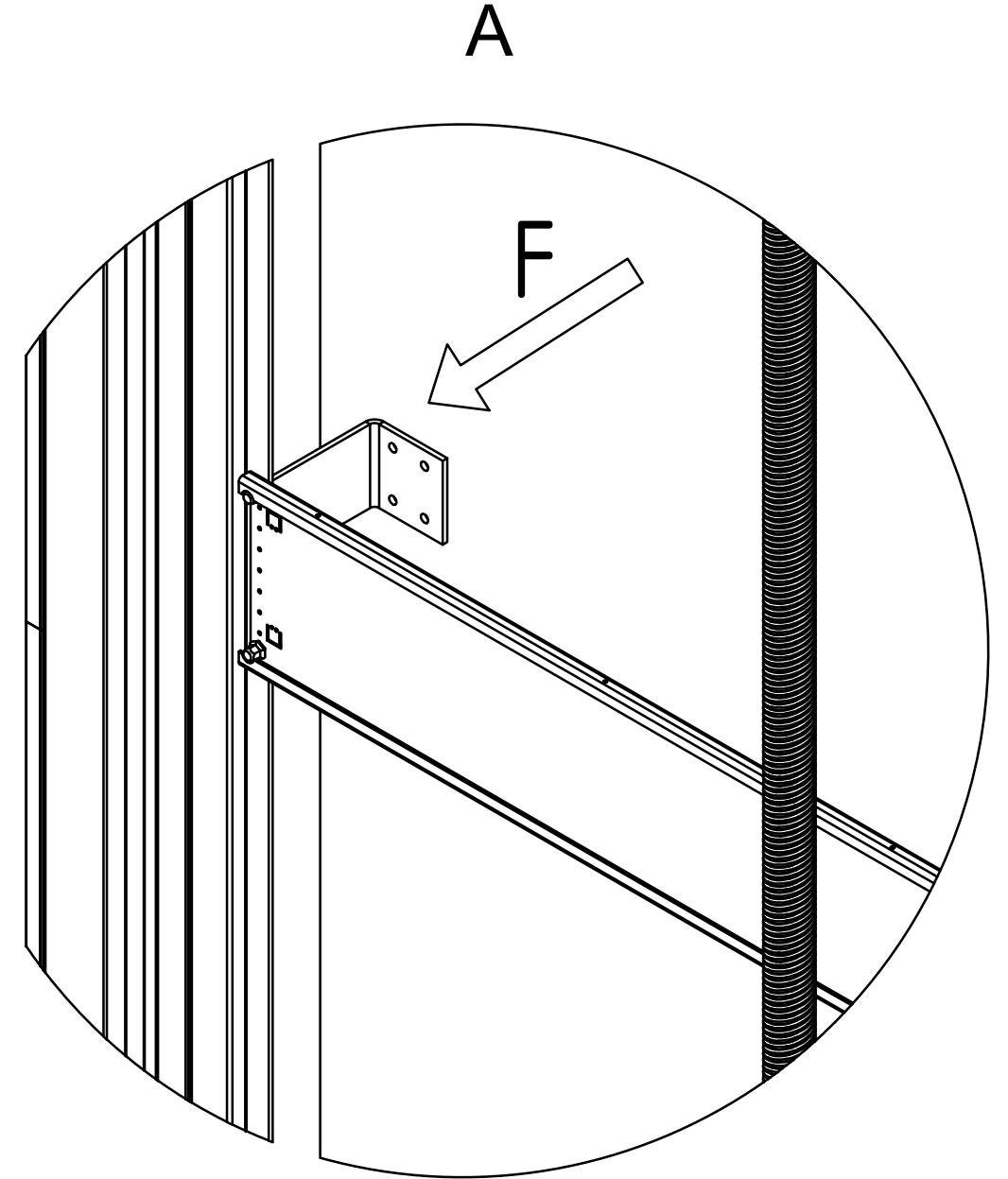
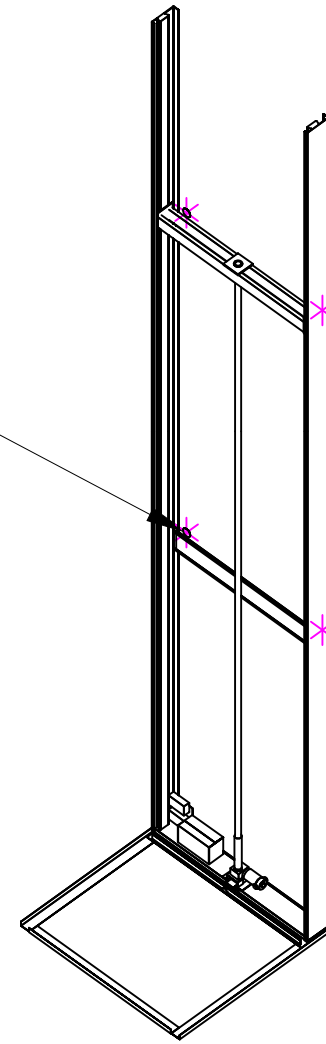

C

C

B

B

A

A

Approved by
builder:



| | | | |
|---------------------|-------------------------|--|--|
| EOS ID L00017807 | Principal drawing | | |
| Tender no | Voyager-1000*1467 | | |
| Order no | Stock29_Ma rinaQatar | | |

European view placement:

| | | | |
|--------------|--------------------|-----------------|---------------------|
| ISO 2768-1 m | Date 2025-04-28 | sheet 3 of 6 | Scale: A3, 1:100 |
|--------------|--------------------|-----------------|---------------------|

6 5 4 3 2 1



A

A

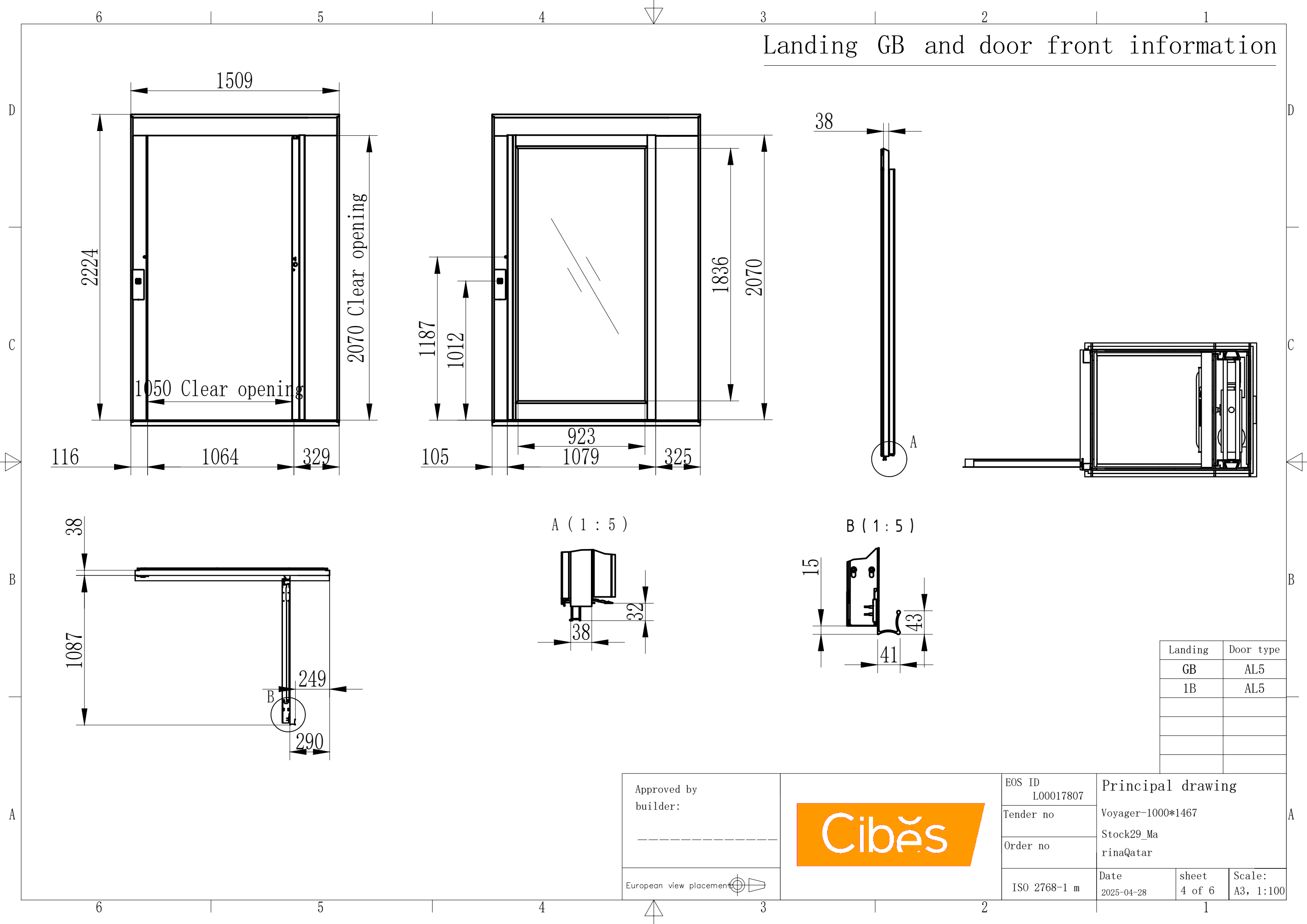
Landing GB and door front information



| Landing | Door type |
|---------|-----------|
| GB | AL5 |
| 1B | AL5 |
| | |
| | |
| | |

| | | | | | |
|---|---|---------------------|-----------------|-------------------------|--|
| Approved by builder: ----- |  | EOS ID L00017807 | | Principal drawing | |
| | | Tender no | | Voyager-1000*1467 | |
| European view placement  | | Order no | | Stock29_Ma rinaQatar | |
| ISO 2768-1 m | | Date 2025-04-28 | sheet 4 of 6 | Scale: A3, 1:100 | |

Landing 1B and door front information

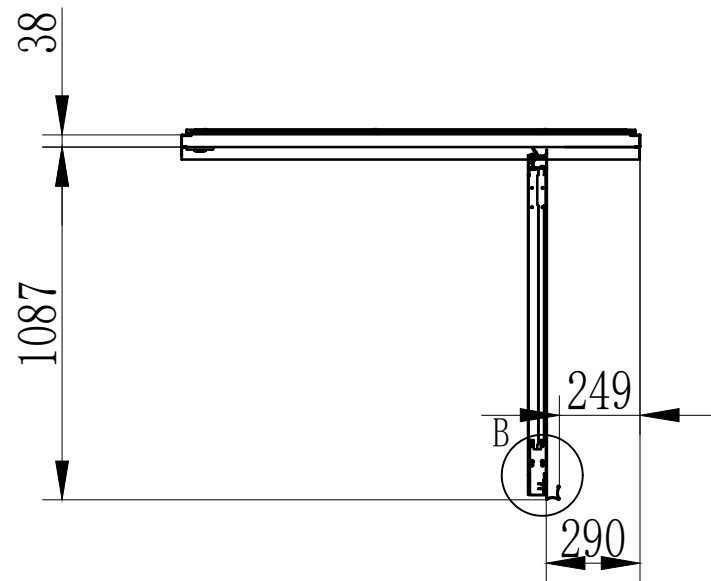
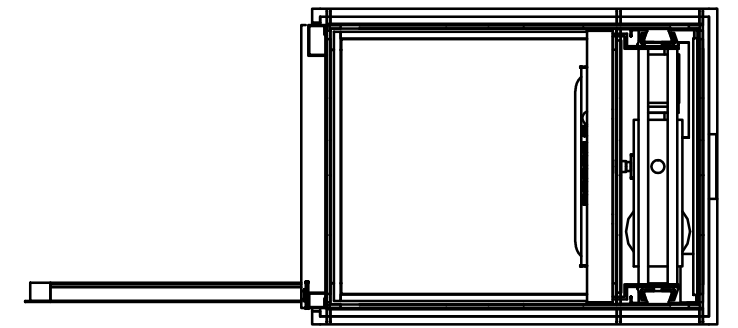
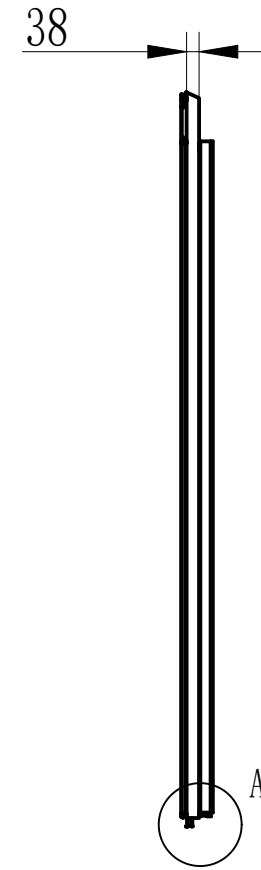
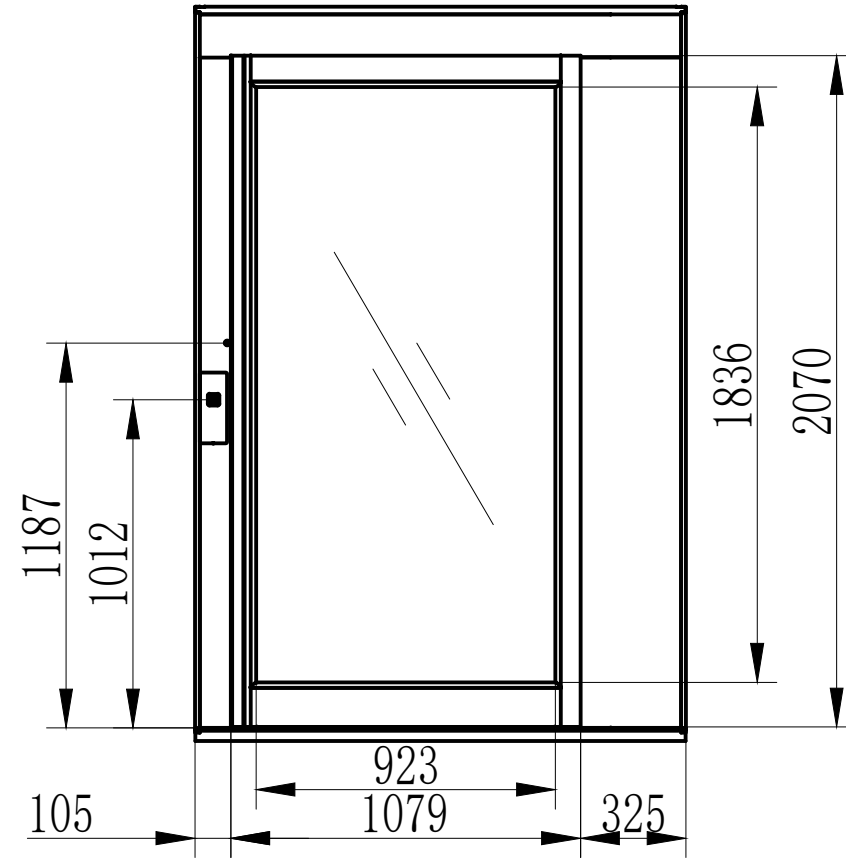
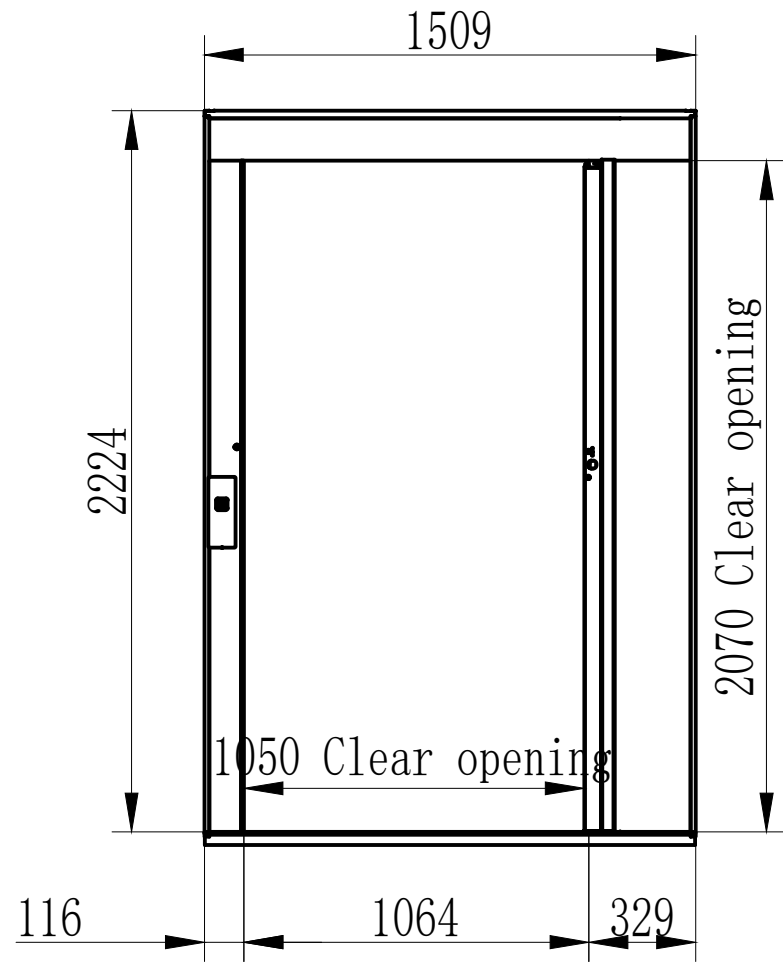

A (1 : 5)

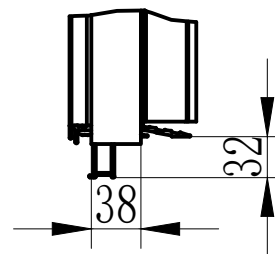

B (1 : 5)

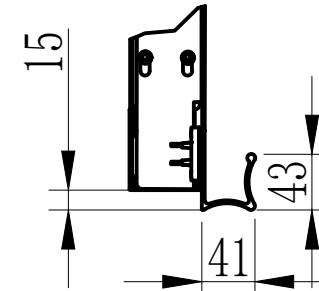

| Landing | Door type |
|---------|-----------|
| GB | AL5 |
| 1B | AL5 |
| | |
| | |
| | |

Approved by
builder:



EOS ID
L00017807

Tender no

Order no

Principal drawing

Voyager-1000*1467

Stock29_Ma

rinaQatar

European view placement

ISO 2768-1 m

| | | |
|--------------------|-----------------|---------------------|
| Date 2025-04-28 | sheet 5 of 6 | Scale: A3, 1:100 |
|--------------------|-----------------|---------------------|

6

5

4

3

2

1

Platform layout

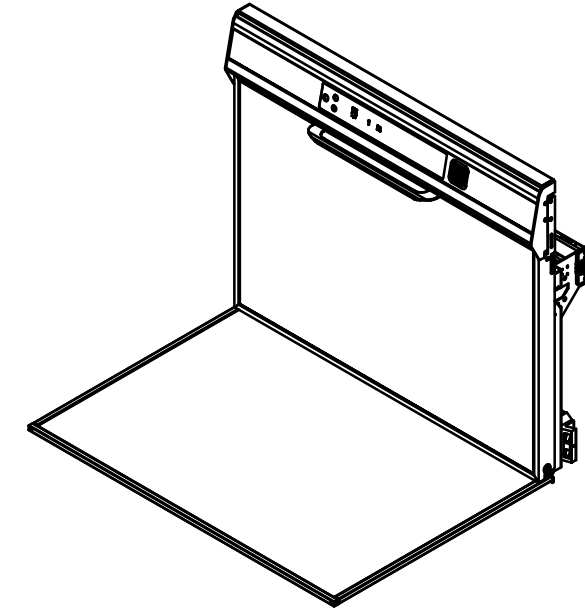
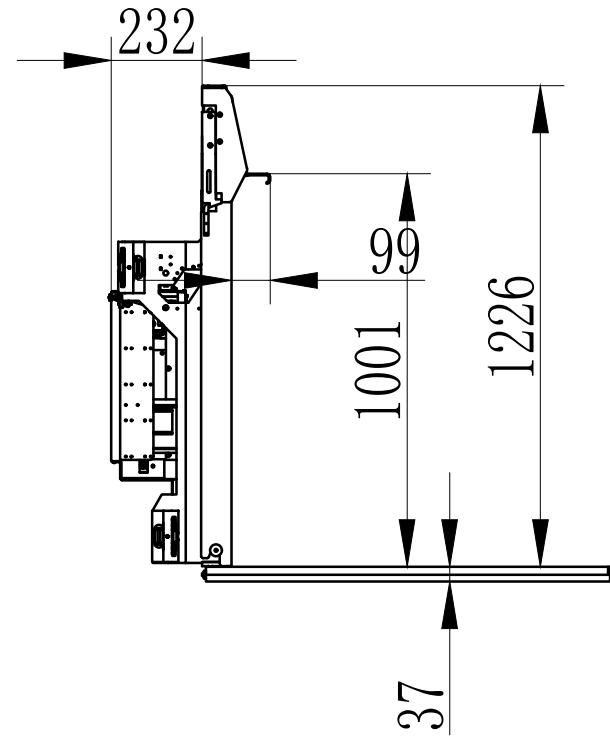
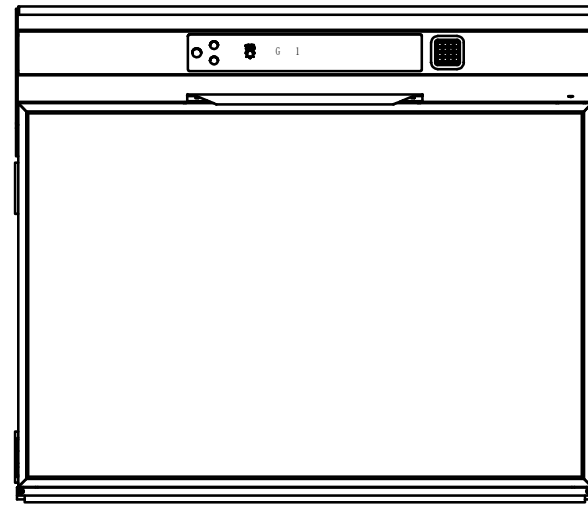

Platform dimensions

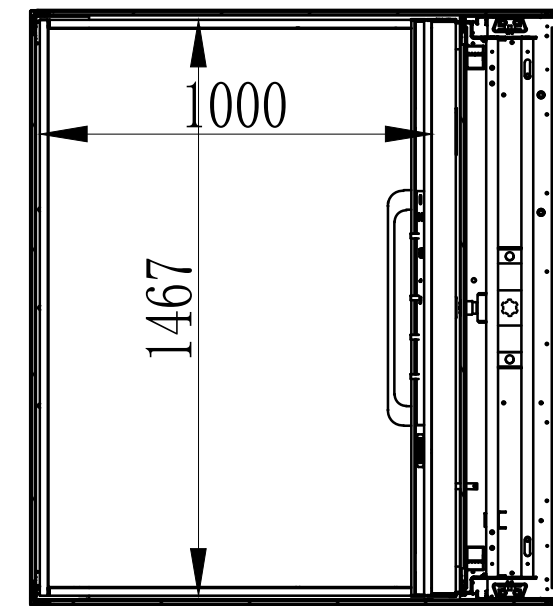

Button layout

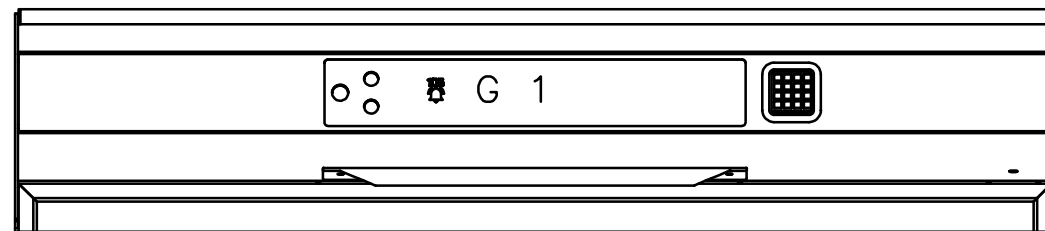

Approved by
builder:

European view placement 



EOS ID
L00017807

Tender no

Order no

ISO 2768-1 m

Principal drawing

Voyager-1000*1467

Stock29_Ma

rinaQatar

Date
2025-04-28

sheet
6 of 6

Scale:
A3, 1:100

6

5

4

3

2

1

D

C

B

A

D

C

B

A